

# USS

## External Louvre



V4M05Y2010/Halton Marine reserves the right to alter products without notice.

- External louvre for air intake and exhaust to prevent rain, snow, leaf and animal ingress
- Rainwater ingress penetration efficiency of approx. 95% (USS/I)
- Operation based on special front edge blade profile and side grooves
- Grille and steel mesh section detachable from outside

- Depth of the blades 65 mm, distance 50 mm and free opening 50%
- Polyester-painted galvanised steel as standard finish

### Product model options and Accessories

- Modular construction available for large sizes
- Models available made of polyester-painted or anodised aluminium, stainless steel (AISI 316) and copper

### MATERIAL AND FINISHING

PART	MATERIAL	FINISHING	NOTE
Fixed blades	Galvanised steel	The standard material is epoxy-painted hot galvanised steel. Special colours and anodising of aluminium are available on request	Optionally aluminium, copper or stainless steel AISI 316
Frame	Galvanised steel	The standard material is epoxy-painted hot galvanised steel. Special colours and anodising of aluminium are available on request	Optionally aluminium, copper or stainless steel AISI 316
Mesh (10 x 10 mm)	Galvanised steel		Stainless steel AISI 316

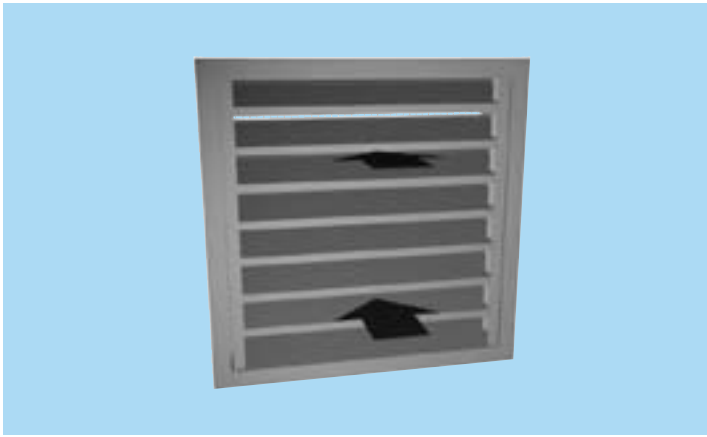

rainwater from entering the ductwork from above. Drops of water are collected in the grooves at the front edge of the blades. Water flows to the side grooves, where it drops down.

**USS blade construction**

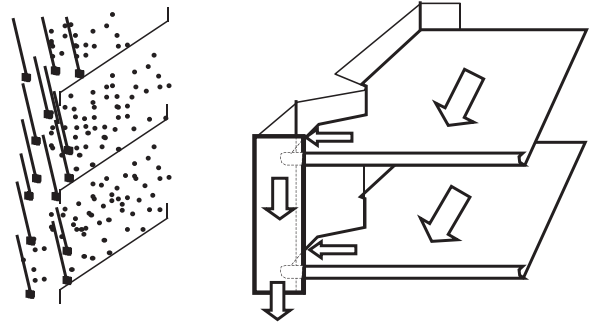

**Function**

Air is supplied or extracted through the horizontal blades. The design of the grille prevents rainwater from reaching the ductwork. The slot between the frame and the top blade is sealed, thus preventing

**QUICK SELECTION**

WxH [mm]	q(1m/s)		q(1,5 m/s)	
	[l/s]	[m³/h]	[l/s]	[m³/h]
400x400	160	576	240	864
400x600	240	864	360	1296
600x400	240	864	360	1296
600x600	360	1296	540	1944
600x1200	720	2592	1080	3888
800x800	640	2304	960	3456
1000x1000	1000	3600	1500	5400
1000x1200	1200	4320	1800	6480

**DIMENSIONS**

L	H
150,+50,...,1200	150,+50,...,1000

At the joint between modules, the L dimension is 105 mm. In addition to standard sizes, other sizes can be specially ordered. The maximum nominal size is 1200x1000 mm.

It is possible to have a continuous grille of modular design when the installation length is greater than 1200 mm. The maximum total length is 20 m.

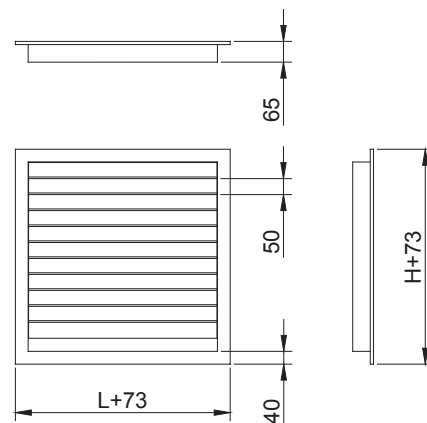

**Pressure drop and sound data**

Air intake  
USS-1000x1000(S)

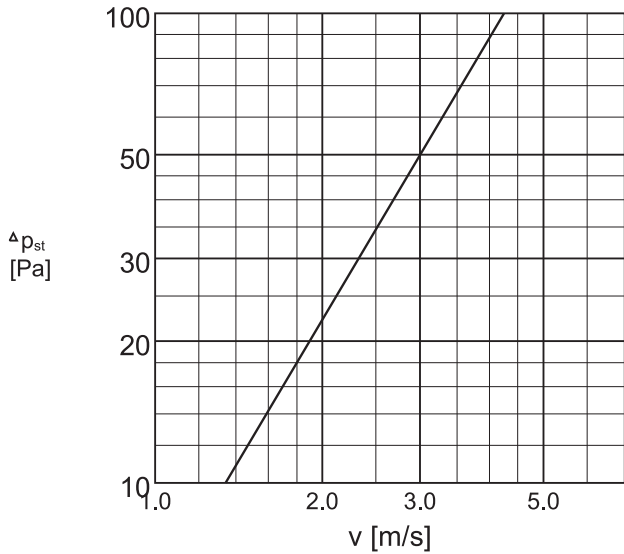

Air exhaust  
USS-1000x1000(E)

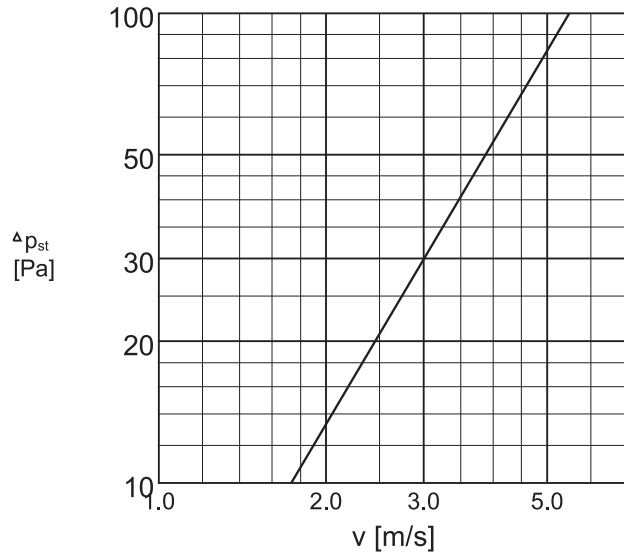

**Water penetration (USS/I)**

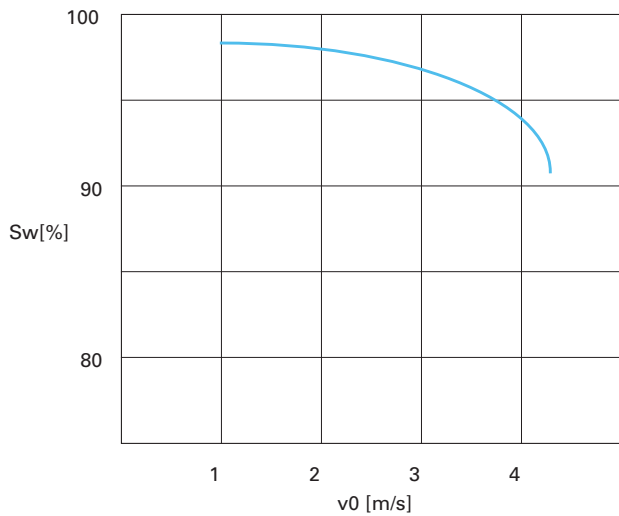

**Snow penetration (USS/I)**

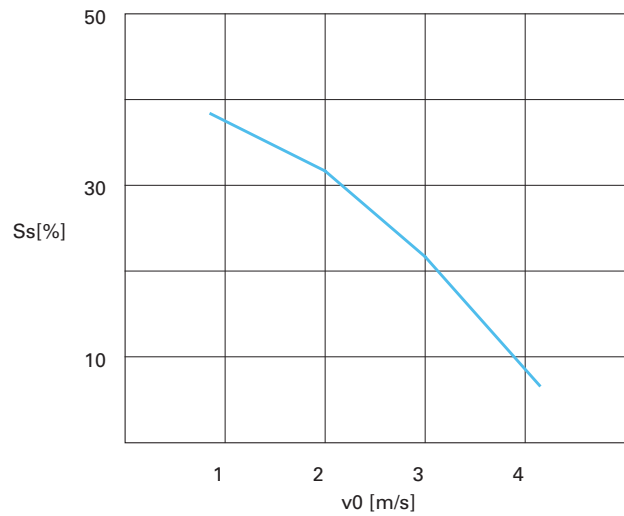

The louvre shall have a rainwater prevention capacity of at least 90% (EUROVENT 2/5). (USS/I)

## Installation

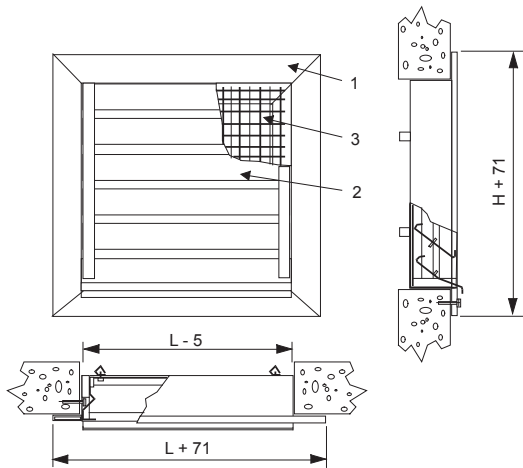

### CODE DESCRIPTION

- |   |            |
|---|------------|
| 1 | Frame      |
| 2 | Blades     |
| 3 | Steel mesh |

The grille is suitable to be screw-fixed into a prepared masonry wall opening.

Drill holes in the flanges of the frame on the site.

The dimensions of the grille are given as the nominal dimensions of the opening.

## Installation of modules

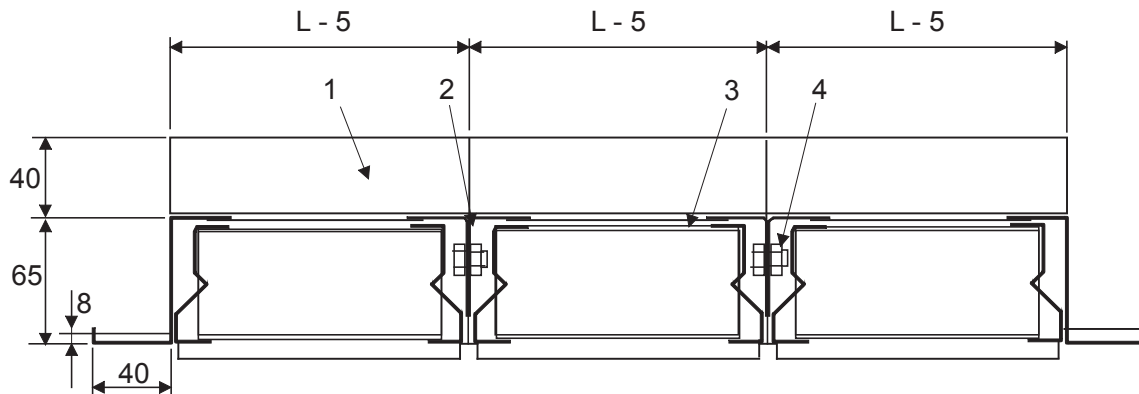

### CODE DESCRIPTION

- |   |                        |
|---|------------------------|
| 1 | Horizontal support     |
| 2 | Vertical support       |
| 3 | Steel mesh             |
| 4 | Bolt and nut (m8 x 10) |

In a modular installation, the frames of adjacent modules can be bolted together, before installation of the grille sections.

If the width or height exceeds 2000 mm, the grille is installed with a supporting installation frame (included in the delivery).

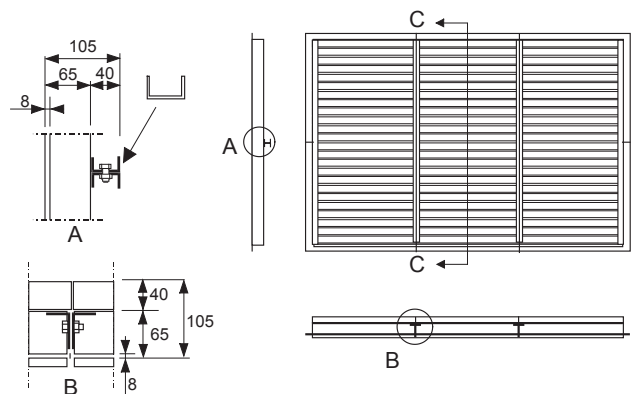

## Servicing

If required, the grille is cleaned with a soft brush.