

BRD

Pressure-Relief Damper



Halton BRD pressure-relief dampers are used in offshore and marine applications to prevent backflow through ventilation ductwork system. The Halton pressure relief dampers do not need an actuator or motor. The BRD dampers can be installed in rectangular or circular ducts horizontally or vertically. Opening pressure can easily be set by adjusting weight of each damper/ installation. Weights are included in the delivery. Pressure relief dampers can be supplied with non-standard dimensions on request.

- Fixed frame in painted, galvanized or stainless steel. Blades of galvanized or stainless steel.
- Models for horizontal or vertical installation
- Blades contain silicone seal to lower the leakage through blades
- ATEX approved
- Closed damper fullfills the leakage requirement of NORSOK. Leakage class of closed damper according to EN 1751 class 2 (VTT test report no. RTE4306/04)
- Blades linked and open in parallel
- Opening pressure adjusted by changing the position of counterweight(s)
- Opening pressure range between 30 Pa and 150 Pa (up to 300 Pa optional)
- Counterweights included
- Standard construction places weights on the right hand side, weights on the left hand side available as an option
- Final adjustment of counterweights carried out during commissioning
- Maximum duct pressure for damper construction 5000 Pa and maximum air velocity 15 m/s. In case of high duct pressure, contact Halton Marine for finding the most suitable solution.

PART	MATERIAL	FINISHING	NOTE
Frame	Carbon steel	Painted or galvanized	-
Frame	Stainless steel	-	-
Blades	Steel	Galvanized	-
Blades	Stainless steel	-	-
Maintenance-free bearings	Stainless steel	-	Bronze bearings optional
Shafts	Stainless steel	-	-

BRD DIMENSIONS AND MATERIAL THICKNESS

BRD pressure relief dampers meet international standards for both rectangular (width B 200-1200 mm and height H 200-1400 mm, 1 mm division) and circular ducts (Ø100 - 1250 mm). Non-standard dimensions are available on request.

Standard flange width 27 mm. Flanges and drilling

also available according to ISO 15138 standards.

Modular construction sizes up to 2400x2800 mm are available. Standard frame material thickness 3 mm.

Blades are made of two sheets, each of being 0.8 mm thick.

GENERAL BRD DRAWING

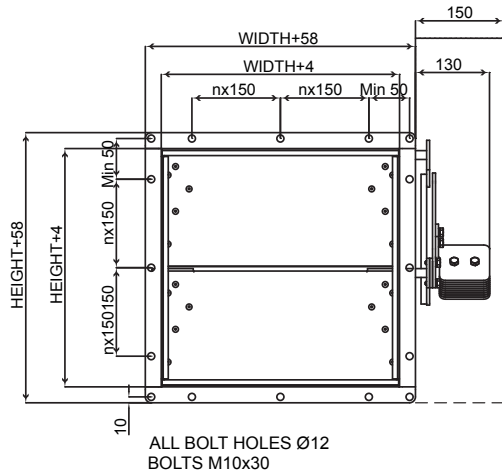

BRD DRAWING TOP

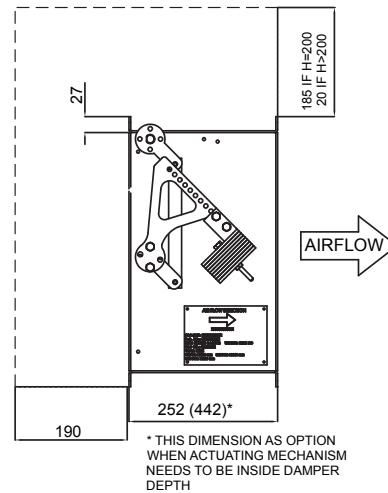

BRD DRAWING, CIRCULAR CONNECTIONS

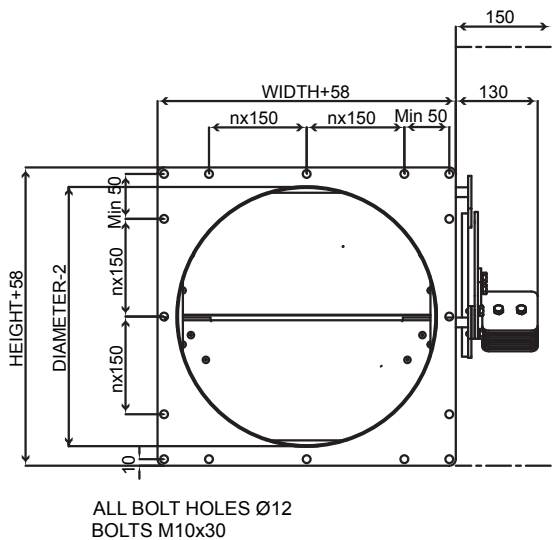

BRD DRAWING, CIRCULAR CONNECTIONS

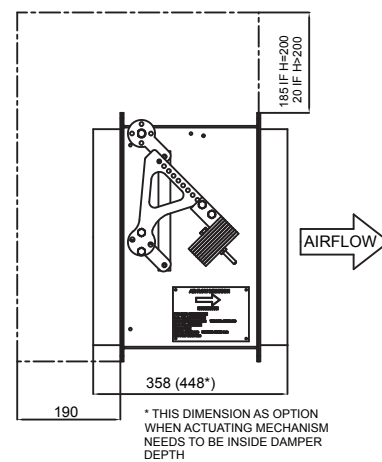

----- operation area

BRD CIRCULAR, WITH CONNECTION FLANGES

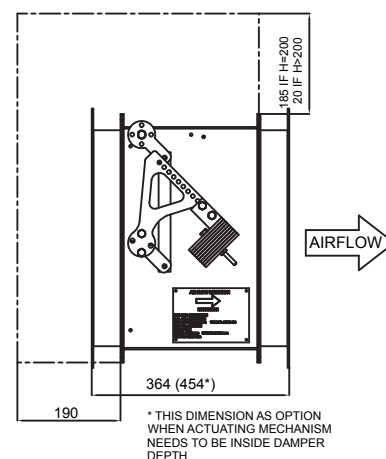

BRD PRODUCT MODELS AND ACCESSORIES

Models for horizontal and vertical installation available.
Circular connection pieces are available.
Standard construction places weights on the right hand side. Weights on the left hand side available as an option.

OPERATION PRINCIPLE

Pressure-relief damper will allow one-way pressure relief in the ductwork. This feature is based on imbalanced blades. When the pressure in the duct rises above selected value (from 30 Pa to 150 Pa, up to 300 Pa optionally) the damper blades open to allow pressure relief. The minimum opening force can be adjusted with weights. When the pressure in the ductwork drops below minimum opening force required, the blades close and seal the duct.

BLD LEAKAGE TEST, DAMPER SIZE 1000x1000

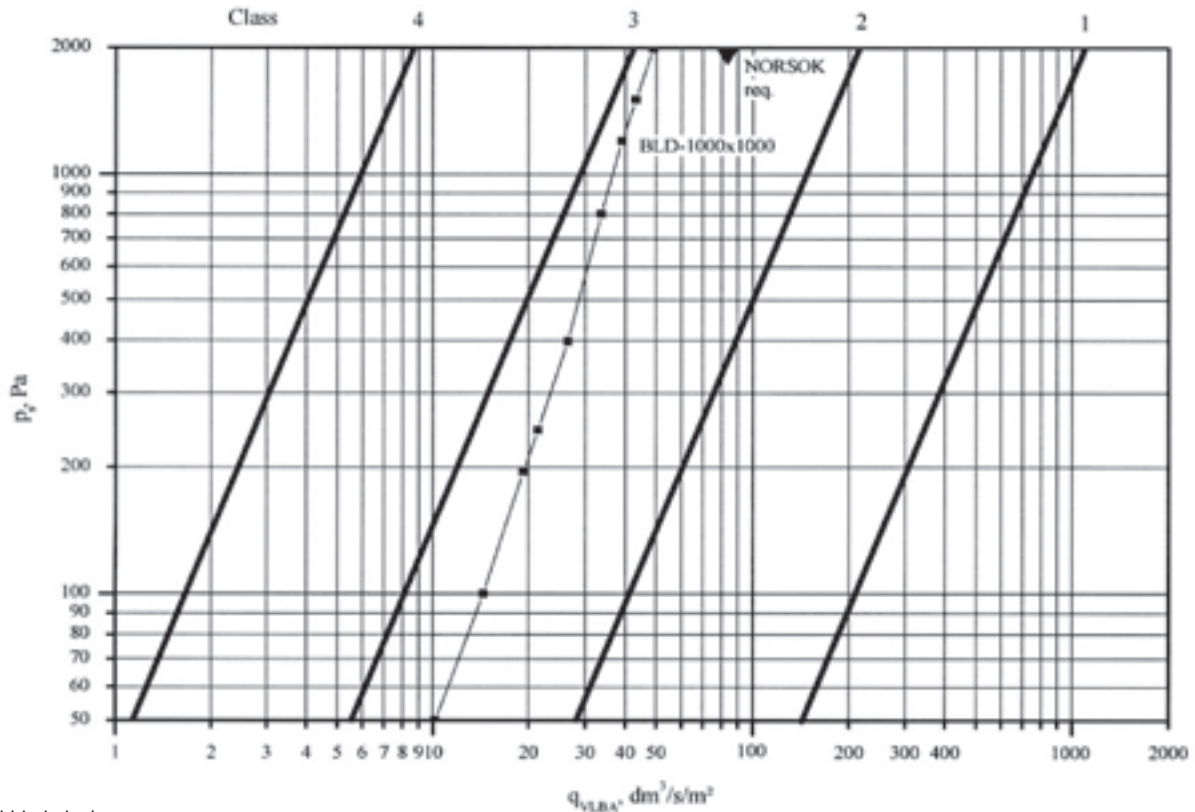

Closed blade leakage.

EN 1751:1998

Duct cross sectional area: 1,00 m²

Air density 1.20 kg/m³

Closed damper fulfills the leakage requirement of NORSOK; maximum leakage 300 m³/h/m² (83,3 dm³/s/m²) at 2000 Pa.

Closed damper fulfills the requirement of leakage class 2 (EN 1751:1998). (negative pressure)

Symbols and units

PsStatic test pressure

qVLBA Closed blade leakage air flow per duct cross sectional area, dm³/s/m²

Note: leakage test done to BLD damper that has a same construction as BRD.

WEIGHTS OF HALTON MARINE BRD DAMPERS (KG)

H/Height mm	B / Width (mm)											D2 ØD mm	Weight kg
	200	300	400	500	600	700	800	900	1000	1100	1200		
200	12	12	14	16	19	20	22	24	26	28	29	200	15
300	13	15	18	20	21	24	26	29	31	34	35	250	17
400	15	18	20	23	25	28	30	33	36	37	40	315	21
500	17	21	24	27	29	32	35	37	40	43	45	400	26
600	20	24	26	29	32	36	39	42	45	47	51	500	36
700	23	26	30	33	37	40	43	47	50	53	57	630	45
800	24	27	33	36	40	43	47	51	54	58	62	800	63
900	28	32	36	39	44	48	52	56	60	63	67	1000	87
1000	30	34	39	43	48	51	55	60	64	68	72	1250	116
1100	33	38	42	47	51	56	60	65	70	72	78		
1200	35	40	45	50	54	59	64	69	74	78	84		
1300	38	44	48	53	58	64	69	74	79	83	89		
1400	40	46	51	56	62	67	73	78	83	88	94		

Weights include counter weights

