

TBM

Square Ceiling Diffuser

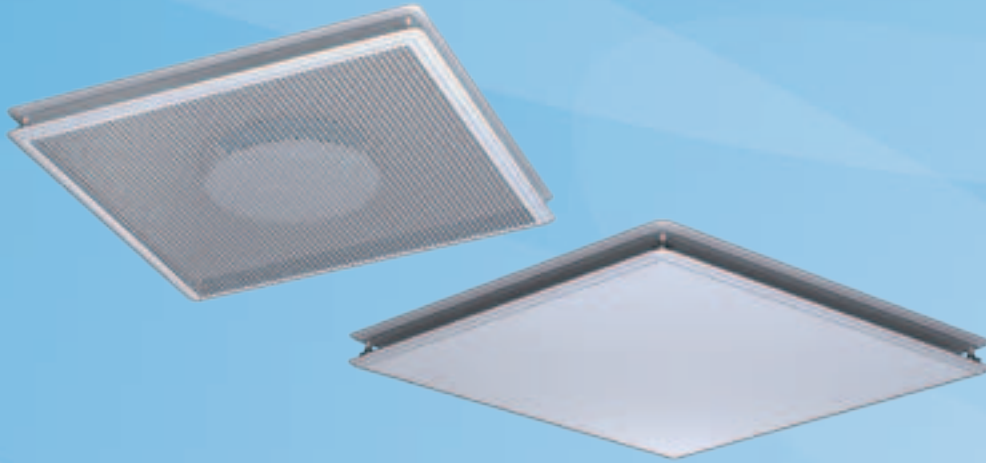

Halton TBM is a square ceiling diffuser for circular duct connections D160...250 mm. The diffuser is manufactured from steel and finished with paint in white RAL 9010 standard colour. Other colours are available on request. The galvanized steel coupling sleeve is equipped with a rubber gasket compound. The diffuser has a solid or perforated front plate. The detachable frontplate is fixed to upper plate springs; cleaning of the diffuser and cabin unit can be carried out through the diffuser. Halton TBM is especially designed for low spaces and is therefore an excellent choice for marine, navy and offshore applications. The TBM is fully compatible with Halton cabin units. A manual cabin unit control knob is available as an option.

- Horizontal radial air supply, suitable also for exhaust
- Installation either to ductwork, balancing plenum or cabin unit
- Detachable front plate enables cleaning of the diffuser
- Circular duct connection with gasket
- Compatible with Halton cabin units
- Control knob for Halton manual cabin unit available as an option

PART	MATERIAL	NOTE
Upper plate	Steel	
Front plate	Steel	TBM/N solid model, TBM/P perforated model
Coupling sleeve	Galvanized steel	Gasket
Duct gasket	Rubber compound	
Finishing	Painted, white RAL9010	Special colours available on request

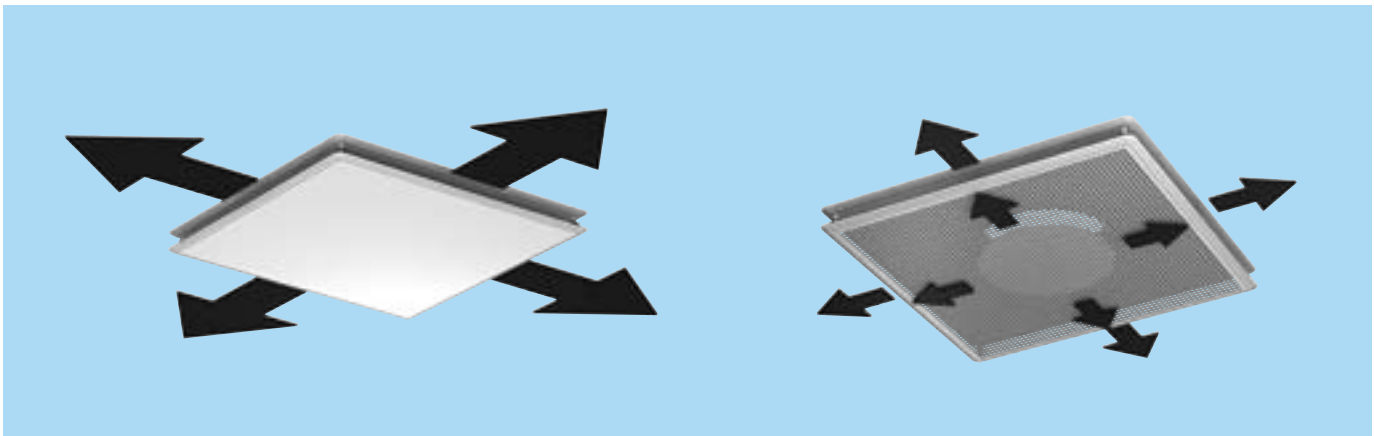

Function TBM/N

Air is supplied horizontally into the space through the side slots of the diffuser and induces the room air outside the diffuser. The recommended maximum air temperature difference between supply and room air is 10 °C degrees.

Function TBM/P

Air is supplied horizontally into the space through the side slots and perforated front panel of the diffuser and mixes with room air outside of the diffuser. The air jet supplied horizontally through the side slots induces room air and mixed supply air. The recommended maximum air temperature difference between supply and room air is 10 °C degrees

Dimensions and weights TBM/N

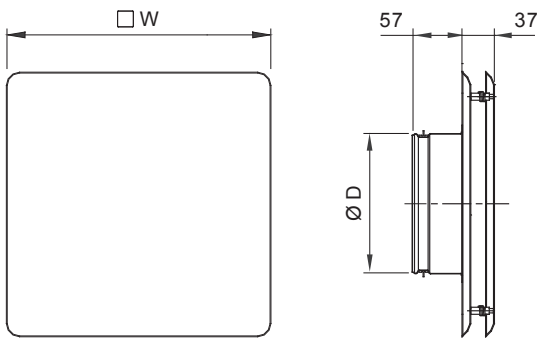

NS	W	ØD	Weight
160	300	159	2,4 KG
200	450	199	3,6 KG
250	450	249	3,6 KG

Dimensions and weights TBM/P

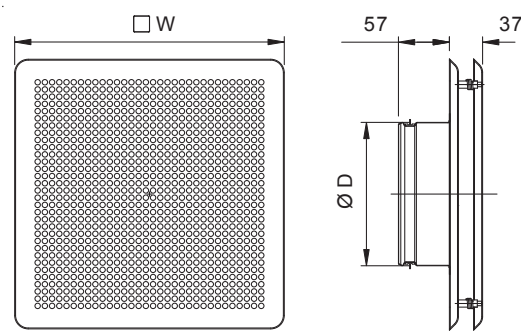

NS	W	ØD	Weight
160	300	159	2,2 KG
200	450	199	3,3 KG
250	450	249	3,3 KG

Installation

The diffuser can be connected to the Halton cabin unit by using duct between cabin unit outlet and diffuser in order to reach the false ceiling level.

Diffuser can be also connected directly in cabin unit outlet. In this case cabin unit outlet has to be female connection.

Diffuser can as well be connected directly to the duct or plenum box.

Servicing

Open the front panel of the diffuser and clean the parts by wiping with a damp cloth. Push the front panel back into place so that the springs lock.

More information

Pressure drop and attenuation data are available from Halton sales office.